



**SJORBAND VOOR AUTOTRANSPORT
 ARRIMAGE TRANSPORT VOITURE
 LASHING STRAP FOR CARTRANSPORT**

DR AT
 Vast deel
 Partie courte
 Short part

DR AT
 Sjordeel
 Partie longue
 Long part

Band Polyester - Sangle en Polyester - Webbing: **35 / 50 mm**

Breekkracht - Résistance à la rupture - Breaking strength: **min. 3.500 kg / 6 & 7,5 Tons**

Gewenst eindbeslag - Pièces d'extrémité à votre choix - Choice of end fitting

Rek - Elongation: **max. 4%**

Volgens - Suivant - According: **EN 12195-2**

Lashing Capacity: **STF 190 daN**

gestrekt
 en traction directe
 straight
 1.500-2.000-2.500 daN

omsnoerd
 en cerclage
 lashed
 3.000-4.000-5.000 daN

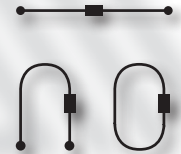

**Ratel
 Tendeur
 Ratchet**

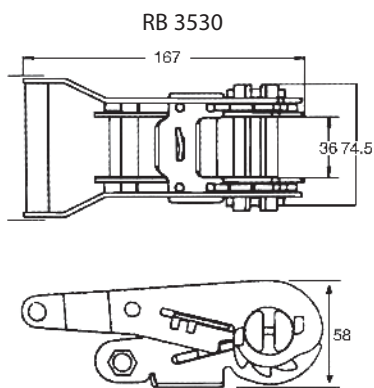

RB 5030

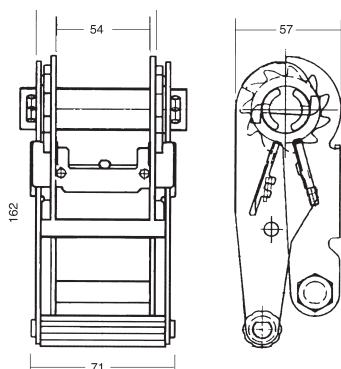

**Eindbeslag
 Pièces d'extrémité
 End fittings**

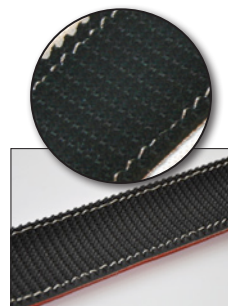

AUTOPROTEC



WHEELBLOCK



RAPROFIL



RAWH 35301 i



RAWH 3530 i



RAWH 3530 WE 35mm
 RAWH 5050 WE 50mm



///BENECA///

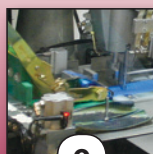

DRAT ALU

LC 1.500 daN / 35 mm
LC 2.000-4.000 daN / 50 mm



Autospanband met velglus, tegen het beschadigen van uw aluminium velgen.
Pour sangler des jantes alu, elle ne laisse ni marque ni trace d'utilisation.
Lashing strap for alloy wheels, as it won't leave any pressure or abrasion marks

BiAUTOLIFT

SWL - CMU: 2.000 Kg (4,2-5,2m)



Auto Hijsbanden gebruik met hijsframe. 300mm band
Tapis de levage véhicules par le bas de caisse à l'aide d'une grue. 300mm sangle
Car lifting Mat with lifting frame. 300mm webbing

BiAUTOLIFT 3-4-5 Lussen - Boucles - Eyes

SWL - CMU: 1.000 Kg

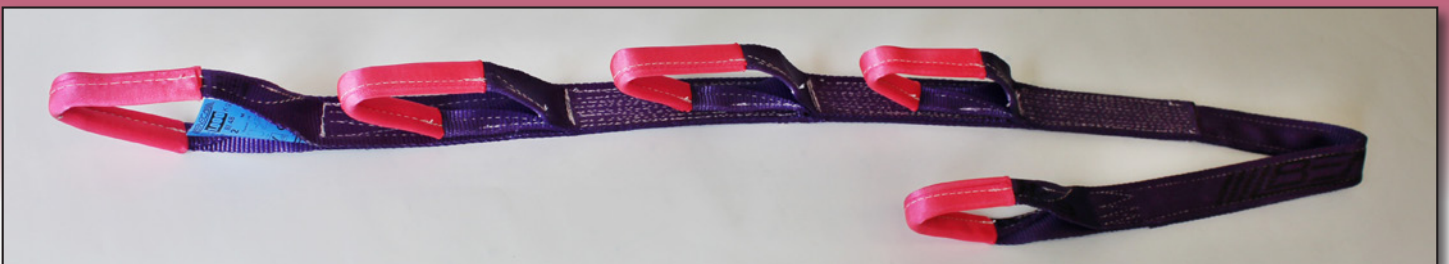

Wielklem hijsbanden.
Sangles pour griffes de roue
Wheel gripper lifting strap

BENECA

